

# Roof fans DVN(I), DVS(I), DVC(I), DHS

Installation and Operating Instructions

GB

Document in original language | · 005

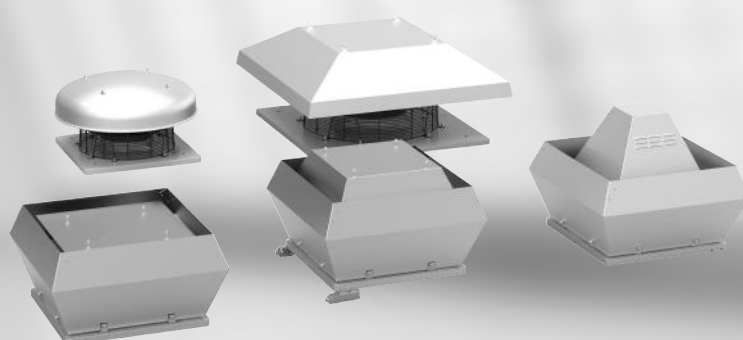

© Copyright Systemair AB  
All rights reserved  
E&OE

Systemair AB reserves the rights to alter their products without notice.  
This also applies to products already ordered, as long as it does not affect the previously agreed specifications.

# Contents

1	General information .....	1	16	EU Declaration of conformity – Roof fans .....	20
1.1	Notice symbols .....	1	17	EU Declaration of conformity – Thermo fans .....	20
1.1.1	Instruction symbols.....	1	18	Commissioning Report.....	21
2	Important safety information .....	1			
2.1	Personnel.....	1			
2.2	Personal protective equipment.....	2			
2.3	5 rules of electrical safety .....	2			
3	Warranty.....	2			
4	Delivery, transport, storage .....	2			
5	Description .....	4			
5.1	Description DVN/DVNI.....	4			
5.2	Description DVS/DVSI .....	5			
5.3	Description DVC/DVCI.....	6			
5.4	Description DHS .....	8			
5.5	Fan and motor data .....	8			
5.6	Intended use .....	8			
6	Name plate and type key .....	9			
7	Accessories.....	10			
8	Installation.....	11			
8.1	Installation of the ventilation system .....	11			
8.1.1	DVC-P pressure tube .....	12			
8.2	Assembly/Disassembly impeller – Internal rotor motor .....	12			
8.3	Assembly tilting device (FTG).....	14			
9	Electrical connection .....	14			
9.1	Electrical connection accessories .....	15			
9.2	Protecting the motor.....	15			
9.3	Variable-speed fans.....	16			
10	Commissioning .....	16			
11	Operation .....	17			
12	Troubleshooting/maintenance/repair .....	17			
12.1	Troubleshooting.....	17			
12.2	Maintenance.....	18			
12.3	Spare parts .....	19			
13	Cleaning.....	19			
14	Deinstallation/dismantling.....	19			
15	Disposal .....	19			



# 1 General information

## 1.1 Notice symbols



### Danger

#### Direct hazard

Failure to comply with this warning will lead directly to death or to serious injury.



### Caution

#### Hazard with a low risk

Failure to comply with this warning may lead to moderate injuries.



### Warning

#### Potential hazard

Failure to comply with this warning may lead to death or serious injury.

### Important

#### Hazard with risk of damage to objects

Failure to comply with this warning will lead to damage to objects.



### Note:

Useful information and instructions

### 1.1.1 Instruction symbols

#### Instruction

- ◆ Carry out this action
- ◆ (if applicable, further actions)

#### Instruction with fixed sequence

1. Carry out this action
2. Carry out this action
3. (if applicable, further actions)

## 2 Important safety information

Planners, plant builders and operators are responsible for the proper assembly and intended use.

- ◆ Read the operating instructions completely and carefully.
- ◆ Keep the operating instructions and other valid documents, such as the circuit diagram or motor instructions, with the fan. They must always be available at the place of use.
- ◆ Observe and respect local conditions, regulations and laws.
- ◆ Abide by the system-related conditions and requirements of the system manufacturer or plant constructor.
- ◆ Safety elements may not be dismantled, circumvented or deactivated.
- ◆ Only use the fan in a flawless condition.
- ◆ Provide generally prescribed electrical and mechanical protective devices.
- ◆ During installation, electrical connection, commissioning, troubleshooting, and maintenance, secure the location and premises against unauthorised access.
- ◆ Do not circumvent any safety components or put them out of action.
- ◆ Keep all the warning signs on the fan complete and in a legible condition.
- ◆ The device is not to be used by persons (including children) with reduced physical, sensory or mental capabilities, or lack of experience and knowledge, unless they have been given supervision or instruction.
- ◆ Do not allow children to play with the device.

### 2.1 Personnel

The fan may only be used by qualified, instructed and trained personnel. The persons must know the relevant safety directives in order to recognise and to avoid risks. The individual activities and qualifications can be found in Table 1 *Qualifications*, page 2.

**Table 1 Qualifications**

Activities	Qualifications	
Storage, operation, transport, cleaning, disposal	Trained personnel (see following note)	
Electrical connection, commissioning, electrical disconnection	Electrical expert or matching qualification	
Installation, disassembly	Fitter or matching qualification	
Maintenance	Electrical expert or matching qualification	Fitter or matching qualification
Repair	Electrical expert or matching qualification	Fitter or matching qualification
	Smoke extraction fans and EX fans only by agreement with Systemair.	

**Note:**

The operator is responsible for ensuring that personnel are instructed and have understood the contents of the operating instructions. If something is unclear, please contact Systemair or its representative.

## 2.2 Personal protective equipment

◆ Wear protective equipment during all work in the vicinity of the fan.

- protective working clothes
- protective working gloves
- goggles
- protective working shoes
- helmet
- hearing protection

## 2.3 5 rules of electrical safety

1. Disconnect (disconnection of the electrical system from live components at all terminals)
2. Prevent reactivation
3. Test absence of voltage
4. Ground and short-circuit
5. Cover or restrict adjacent live parts

## 3 Warranty

For the assertion of warranty claims, the products must be correctly connected and operated, and used in accordance with the data sheets. Further prerequisites are a completed maintenance plan with no gaps and a commissioning report. Systemair will require these in the case of a warranty claim. The commissioning report is a component of this document. The maintenance plan must be created by the operator, see section 12.2 *Maintenance*, page 18.

## 4 Delivery, transport, storage

### Safety information

#### Warning: Risk from rotating fan blades

◆ Prevent access by unauthorised persons by safety personnel or access protection.

#### Warning: Suspended loads

- ◆ Wear protective equipment during all work in the vicinity of the fan, details see 2.2 *Personal protective equipment*, page 2.
- ◆ Do not walk under suspended loads.
- ◆ Make sure that there is nobody under a suspended load.

### Delivery

Each fan leaves our plant in an electrically and mechanically proper condition. We recommend transporting the fan to the installation site in the original packaging.

**Checking delivery**

- ◆ Check the packaging and the fan for transport damage. Any findings should be noted on the cargo manifest.
- ◆ Check completeness of the delivery.

**Unpacking****Warning**

**When opening the transport packaging, there is a risk of damage from sharp edges, nails, staples, splinters etc.**

- ◆ Unpack the fan carefully.
- ◆ Check the fan for obvious transport damage.
- ◆ Only remove the packaging shortly before assembly.
- ◆ Wear protective equipment during all work in the vicinity of the fan, details see 2.2 *Personal protective equipment*, page 2.

**Transport****Safety information**

**Warning: Electrical or mechanical hazards due to fire, moisture, short circuit or malfunction.**

- ◆ Never transport the fan by the connecting wire, terminal box, impeller, protection grille, inlet cone or silencer.
- ◆ In open transport, please make sure that no water can penetrate into the motor or other sensitive parts.
- ◆ We recommend transporting the fan to the installation site in the original packaging.

**Caution: If transported without care during loading and unloading, the fan may be damaged.**

- ◆ Load and unload the fan carefully.
- ◆ Use hoisting equipment that is suitable for the weight to be hoisted.
- ◆ Observe the transportation arrows on the packaging.
- ◆ Use the fan packaging exclusively as transport protection and not as a lifting aid.

**Storage**

- ◆ Store the fan in the original packaging in a dry, dust-free location protected against weather.
- ◆ Avoid the effects of extreme heat or cold.

**Important**

**Hazard due to loss of function of the motor bearing**

- ◆ Avoid storing for too long (recommendation: max. 1 year).
- ◆ Check that the motor bearing functions properly before installation.

## 5 Description

### Roof fans equipped with an EC motor

The fans are driven by EC motors. These motors are delivered with a pre-wired potentiometer (0–10 V) that allows you to easily find the required working point of the fan. All motors are suitable for 50/60 Hz. The input voltage for single-phase units can vary between 200 and 277 V for three phase units between 380 and 480 V. All models have one potential-free terminal for error message.

### Roof fans equipped with an AC motor

For information on speed regulation options, see 6 *Name plate and type key*, page 9.

## 5.1 Description DVN/DVNI

**Table 2 Dimensions DVN**

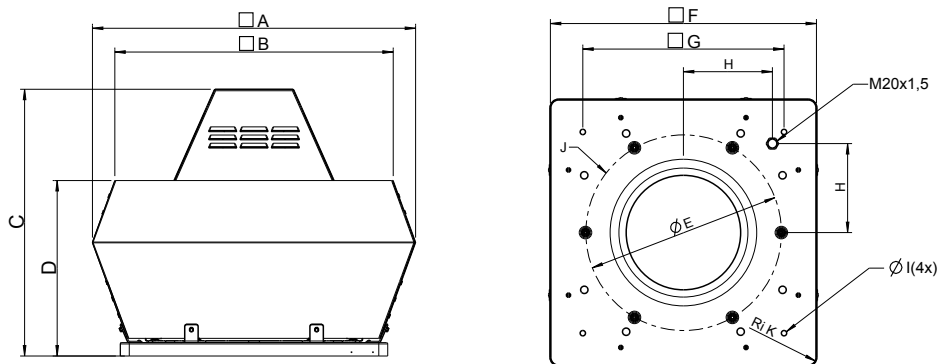

[mm]	A	B	C	D	E	F	G	H	I	J	K
355–400	720	618	600	390	438	595	450	200	12(4x)	6xM8	18.5
450–500	900	730	675	465	438	665	535	237	12(4x)	6xM8	18.5
560–630	1150	955	900	560	605	939	750	293	14(4x)	8xM8	0
710	1350	1178	936	660	674	1035	840	320	14(4x)	8xM8	0
800–900	1690	-	1180	830	872	1255	1050	433	14(4x)	8xM8	0

**Table 3 Dimensions DVNI**

[mm]	A	B	C	D	E	F	G	H	I	J	K
355–400	874	648	600	439	438	595	450	200	12(4x)	6xM8	18.5
450–500	970	730	675	479	438	665	535	237	12(4x)	6xM8	18.5
560–630	1315	1035	900	600	605	939	750	293	14(4x)	8xM8	0
710	1483	1165	936	729	674	1035	840	320	14(4x)	8xM8	0
800–900	1590	-	1180	830	872	1255	1050	433	14(4x)	8M8	0



## 5.2 Description DVS/DVSI

Table 4 Dimensions DVS

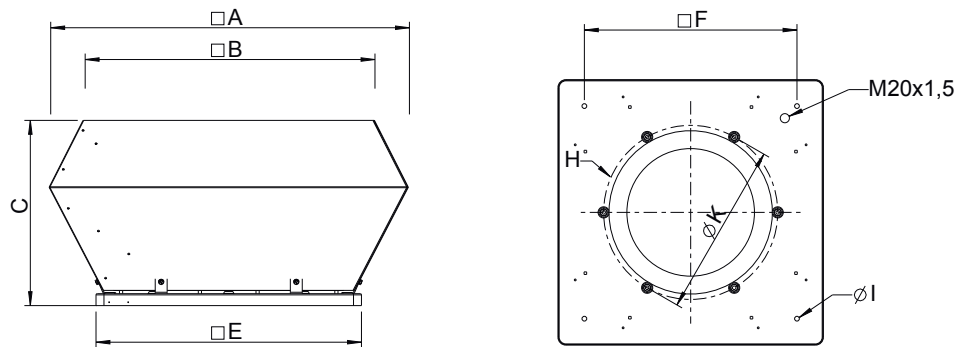

[mm]	A	B	C	E	F	H	K	I
190-225	370	320	175	335	245	6xM6	213	10(4x)
310-311	560	470	330	435	330	6xM8	285	10(4x)
355-400	723	623	390	595	450	6xM8	438	12(4x)
450-500	900	730	465	665	535	6xM8	438	12(4x)
560-630	1150	960	565	939	750	8xM8	605	14(4x)
710	1350	1185	660	1035	840	8xM8	674	14(4x)

Table 5 Dimensions DVSI

[mm]	A	B	C	E	F	H	K	I
190-225	498	438	210	335	245	6xM6	213	10(4x)
310-311	695	584	370	435	330	6xM8	285	10(4x)
355-400	877	745	440	595	450	6xM8	438	12(4x)
450-500	970	825	479	665	535	6xM8	438	12(4x)
560-630	1315	1130	600	939	750	8xM8	605	14(4x)
710	1483	1185	729	1035	840	8xM8	674	14(4x)

### 5.3 Description DVC/DVCI

**S-Version:**

The DVC-S version can be stepless controlled via a 0-10 V signal. The operating point can be directly adjusted with the integrated potentiometer (10 K ohms).

**POC-Version**

The DVC-POC version has integrated pressure sensors and temperature sensor for outdoor temperature compensation. The electronics can be programmed for a constant pressure operation with or without outdoor temperature compensation (The factory setting is with outdoor temperature compensation). For any details of the controller, please see the separate attached controller manual.

**P-Version:**

The DVC-P version has integrated pressure sensors and the electronic is programmed for a constant pressure operation. For any details of the controller, please see the separate attached controller manual.

This version can also be ordered as CAV (constant air volume).

**Table 6 K-factor (measured values) DVC-P**

315-P EC	103	450-P EC	245	560-P EC	298
355-P EC	143	450-K-P EC	253	630-P EC	498
400-P EC	207	500-P EC	365	710-P EC	628

**Table 7 Dimensions DVC-S**

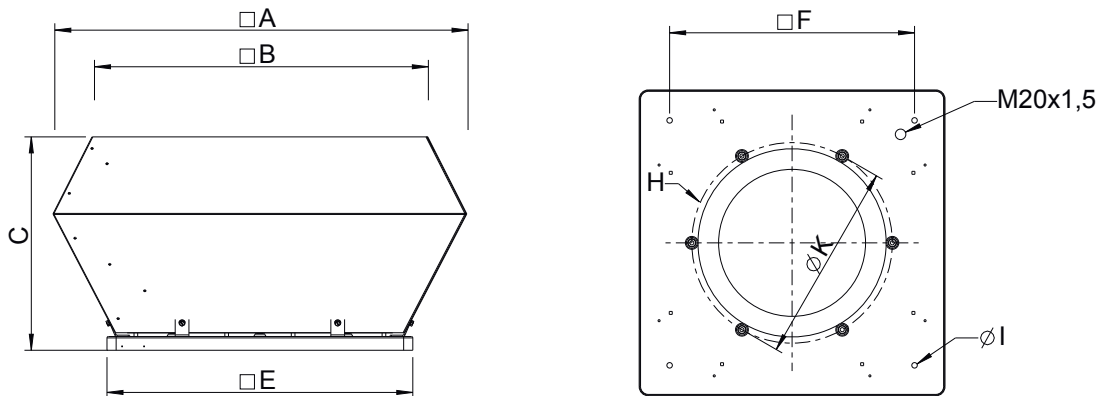

[mm]	A	B	C	E	F	H	K	I
190-225	370	320	175	335	245	6xM6	213	10(4x)
315	560	470	330	435	330	6xM8	285	10(4x)
355-400	723	623	390	595	450	6xM8	438	12(4x)
450-500	900	730	465	665	535	6xM8	438	12(4x)
560-630	1150	960	565	939	750	8xM8	605	14(4x)

**Table 8 Dimensions DVCI-S**

[mm]	A	B	C	E	F	H	K	I
190-225	498	438	210	335	245	6xM6	213	10(4x)
315	695	584	370	435	330	6xM8	285	10(4x)
355-400	874	648	439	595	450	6xM8	438	12(4x)
450-500	970	730	479	665	535	6xM8	438	12(4x)
560-630	1315	1130	600	939	750	8xM8	605	14(4x)

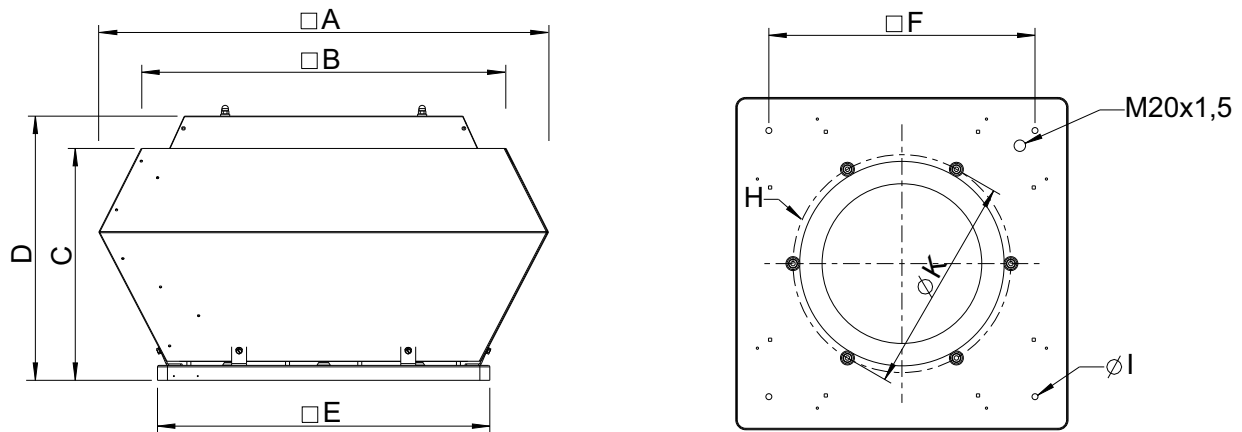
**Table 9 Dimensions DVC-P/DVC-POC**

[mm]	A	B	C	D	E	F	H	K	I
190-225	370	320	175	-	335	245	6xM6	213	10 (4x)
315	560	470	330	378	435	330	6xM8	285	10 (4x)
355-400	723	623	390	438	595	450	6xM8	438	12 (4x)
450-500	900	730	465	515	665	535	6xM8	438	12 (4x)
560-630	1150	960	565	585	939	750	8xM8	605	14(4x)

**Table 10 Dimensions DVCI-P/DVCI-POC**

[mm]	A	B	C	D	E	F	H	K	I
225	498	438	210	-	335	245	6xM6	213	10(4x)
315	690	583	369	415	435	330	6xM6	285	10(4x)
355-400	877	745	440	439	595	450	6xM8	438	12(4x)
450-500	970	825	479	516	665	535	6xM8	438	12(4x)
560-630	1315	1135	600	619	939	750	8xM8	605	14(4x)

## 5.4 Description DHS

The fans are equipped with AC motors. For information on speed regulation options, see 6 *Name plate and type key*, page 9.

**Table 11 Dimensions DHS**

	size 190 to 500 → round cap				size 560 to 710 → squared cap			
[mm]	<b>A</b>	<b>C</b>	<b>E</b>	<b>F</b>	<b>H</b>	<b>K</b>	<b>I</b>	
190-225	417	150	335	245	6xM6	213	10(4x)	
310-315	540	250	435	330	6xM8	285	10(4x)	
355-400	720	330	595	450	6xM8	438	12(4x)	
450-500	830	490	665	535	6xM8	438	12(4x)	
560-630	1100	535	939	750	8xM8	605	14(4x)	
710	1282	580	1035	840	8xM8	674	14(4x)	

## 5.5 Fan and motor data

- Max. temperature of transported air, max. ambient temperature, sound pressure → see data sheet, available in our online catalogue.
- Voltage, current, enclosure class, weight → see name plate
- The motor data can be found on the name plate of the motor, or in the technical documents of the motor manufacturer.

## 5.6 Intended use

### All roof fans

- The fans are intended for installation in ventilation systems. They can be installed both in duct systems and also with free suction via an inlet cone and a suction-side contact protection grille. Systemair recommends a Back draft damper (VKS) to avoid cold air intake at a standstill of the fan, see 7 *Accessories*, page 10.
- The maximum permissible operating data on the name plate apply for an air density of 1.2 kg/m<sup>3</sup> (sea level) and a max. air humidity of 80 %.
- The fans are exclusively intended for extract air applications.

### DVN, DVNI

- The fan is suitable for conveying contaminated air (dust, kitchen exhaust), with a density of 1.3 kg/m<sup>3</sup> and a max. air humidity of 95 %.

### DVS, DVSI, DVC, DVCI, DHS





- The fan is suitable for conveying clean air, with a density of 1.3 kg/m<sup>3</sup> and a max. air humidity of 95 %.

### Incorrect use

Incorrect use refers mainly to using the fan in another way to that described. The following examples are incorrect and hazardous:

- Conveying of explosive and combustible media
- Conveying of aggressive media
- Operation in an explosive atmosphere
- Operation without duct system or protection grille
- Operation with the air connections closed

## 6 Name plate and type key

1	<b>DVN 500D4 IE2</b>						
2	400 V	3,39 A	50Hz				8
3	 1361 W						
4	tF=120°C						
5	IP55	1400 min <sup>-1</sup>	57,4kg				
6	INS. CL. F						
7	SerialNo.: 32185/2596796-001/20161004						

- |   |                                     |   |   |
|---|-------------------------------------|---|---|
| 1 | Type designation                    | 5 | Enclosure class/fan impeller speed/weight           |
| 2 | Voltage/current/frequency           | 6 | Insulation class                                    |
| 3 | Input power                         | 7 | Article number/production number/manufacturing date |
| 4 | Max. temperature of transported air | 8 | Certifications                                      |

**Table 12 Type key**

DVN	500	-	D4	
				<b>Motor type</b>
				EC   Electronically commutated/1 phased or 3 phased
				E2   2 poled/controllable by frequency converter/1 phased
				E4   4 poled/controllable by frequency converter/1 phased
				E6   6 poled/controllable by frequency converter/1 phased
				DV   4 poled voltage controllable/3 phased
				DS   6 poled voltage controllable/3 phased
				EZ   2 poled voltage controllable/1 phased
				EV   4 poled voltage controllable/1 phased
				ES   6 poled voltage controllable/1 phased
				D4   4 poled/controllable by frequency converter/3 phased
				D6   6 poled/controllable by frequency converter/3 phased
				<b>Only at DVC</b>
				S   Controllable via a 0-10 V signal
				P   Integrated pressure sensors
				POC   Integrated pressure sensors and temperature sensor
				Size
				<b>Fan type</b>
				DVN   Roof fan - vertical discharge - high temperature
				DVNI   Roof fan - vertical discharge - high temperature - insulated
				DVS   Roof fan - vertical discharge - standard
				DVSI   Roof fan - vertical discharge - standard - insulated
				DVC   Roof fan - vertical discharge - ec motor
				DVCI   Roof fan - vertical discharge - ec motor - insulated
				DHS   Roof fan - horizontal discharge - standard

## 7 Accessories

For details of the accessories, please check our online catalog or contact Systemair.

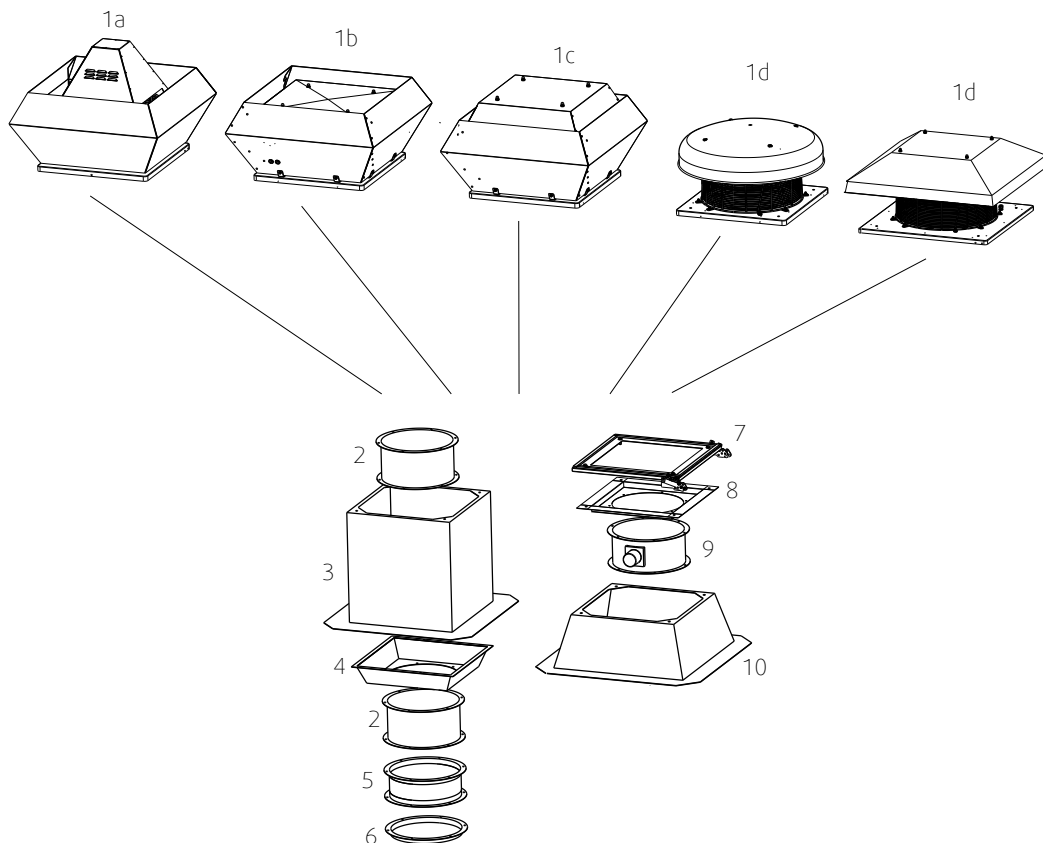

**Table 13 Accessories**

1a	DVN, DVNI	Roof fan - vertical discharge - high temperature - (insulated)			
1b	DVS/DVSI	Roof fan - vertical discharge - standard - (insulated)			
1c	DVC/DVCI	Roof fan - vertical discharge - ec motor - (insulated)			
1d	DHS	Roof fan - horizontal discharge - standard size 190 to 500 → round cap size 560 to 710 → squared cap			
2	VKS (ii)	Back draft damper	7	FTG (iii)	Tilting device
3	SSD (i)	Socket silencer	8	TDA	Adapter framework
4	ASK	Inflow box SSD	9	VKM (ii)	Back draft damper (motor driven)
5	ASS	Flexible connection	10	FDS (i)	Flat roof socket
6	ASF	Inlet flange			



### Note:

- i. Size 190–450: If the degree of inclination is higher than 15°, a SSS (Slanting socket silencer) or a SDS (Slanting roof socket) has to be used.  
Size 499–630: If the degree of inclination is higher than 10°, a SSS (Slanting socket silencer) or a SDS (Slanting roof socket) has to be used.
- ii. Do not install a VKS (self-actuating back draft damper) for roof fans (e.g. P version, POC version) which are controlled by sensors in the duct system. In this case, you must use a VKM (motor-driven back draft damper).
- iii. See chapter 8.3 *Assembly tilting device (FTG)*, page 14

## 8 Installation

### Safety information

#### **Warning: Danger from falling fan or fan parts.**

- ◆ Check the surface before installation for load bearing capacity.
- ◆ Consider all static and dynamic loads when selecting hoisting equipment and fastening components.

#### **General safety information**

- ◆ Installation may only be carried out by adequately qualified persons, details see Table 1 *Qualifications*, page 2.
- ◆ Move the rotor of the fan by hand before you install it in order to check that it moves freely.
- ◆ Provide contact and intake protection and ensure safety distances according to DIN EN ISO13857 and DIN 24167-1.
- ◆ Prevent the possibility of foreign bodies being drawn in.
- ◆ To reduce transmission of vibration to the duct system, we recommend flexible connections from our accessory range, see chapter Accessories.

### Preconditions

- ◆ Ensure that the fan and all its components are undamaged.
- ◆ Ensure that there is enough space to install the fan.
- ◆ Protect against dust and moisture when installing.
- ◆ Ensure that the information on the name plates (fan and motor) matches up with the operating conditions.
- ◆ Fit the fans in such a way that there is sufficient access for troubleshooting, maintenance and repair.

### 8.1 Installation of the ventilation system

#### **Important**

##### **Leaking roof due to wrong installation.**

- ◆ The roof seal (e.g. plastic or bitumen foil) has to be pulled and fixed under the base plate of the roof fan, see below picture.

#### **Important**

##### **Leaking duct system.**

- ◆ When installing the roof fan and accessories all mounting surfaces have to be sealed air tight.

#### **Important**

##### **Condensate formation due to thermal bridge.**

If the fan and the accessories are insufficiently insulated, condensation may form.

1. Check if the fan and accessories form a thermal bridge.
2. Insulate the fan and accessories sufficiently.

- 1 Base plate of the roof fan
- 2 SSS Slanting socket silencer
- 3 Roof seal e.g. plastic or bitumen foil
- 4 Isolation
- 5 Roof construction

The below installation diagram is an example.

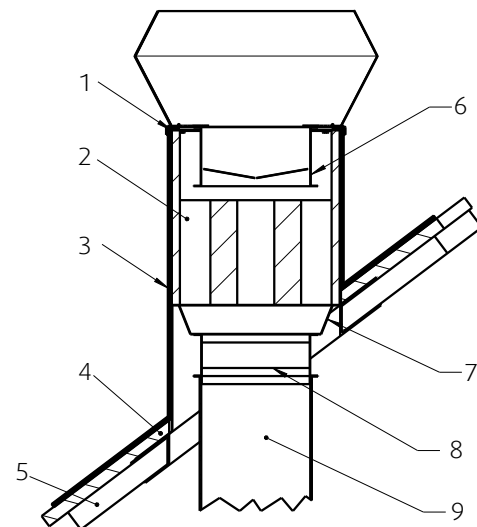

- 6 VKS/VKM Back draft damper
- 7 Has to be realized on-site
- 8 ASS Flexible connection
- 9 Duct system

**Important**

**Damage to the bearings or other parts of the fan can occur.**

- ◆ Do not place a duct bend directly before or after the fan!
- ◆ Ensure a smooth and constant air flow to the device. Ensure a free exhaust. See .

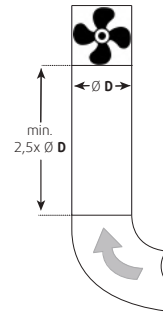

- Rectangular duct system: **D** = Hydraulic diameter
- Round duct system: **D** = Nominal diameter

### 8.1.1 DVC-P pressure tube

The following illustrations show the schematic installation of the pressure tubes.

Size  
190-225

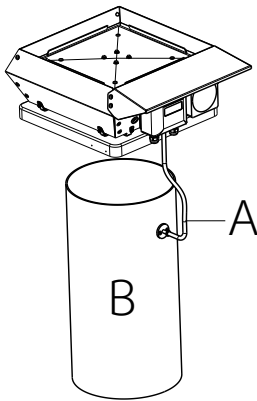

- A Pressure tube
- B Duct system

Controller input

- Duct system
- + Atmosphere

Size  
315-710

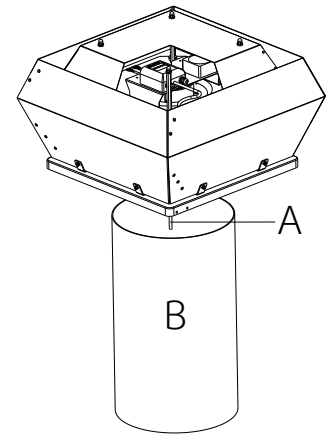

### 8.2 Assembly/Disassembly impeller – Internal rotor motor

If an external rotor motor is used, the motor and impeller can't be separated.

**Important**

**Damage to the motor and impeller.**  
The ball bearing of the motor and the balanced impeller may be damaged by forceful impacts.

- ◆ Attach the impeller and/or the shaft extension to the shaft or the rotor without forceful impacts.
- ◆ **Do not separate the impeller and the hub. They were balanced as one unit by Systemair.**



**Note:**

The hub can be heated for easier assembly and disassembly, for example with a hot-air blower.

- Precondition for assembly: the wedge is in the intended groove.
- Tools: hexagon socket wrench and suitable tool for removal, torque wrench for the taper clamping bush.



- 1 Motor
- 2 Motor shaft
- 3 Sleeve (not available at every fan)
- 4 Shaft extension (not available at every fan)
- 5 Hexagon socket screw
- 6 Impeller
- 7 Steel hub
- 8 Aluminium hub

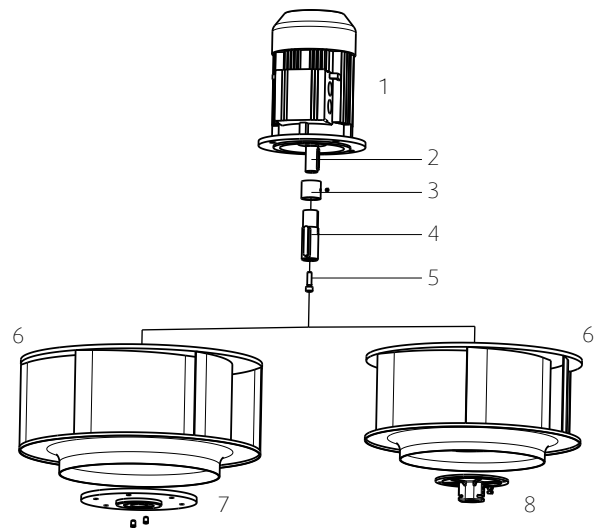

The hub is shown without impeller due to better lucidity.

**Disassembly**

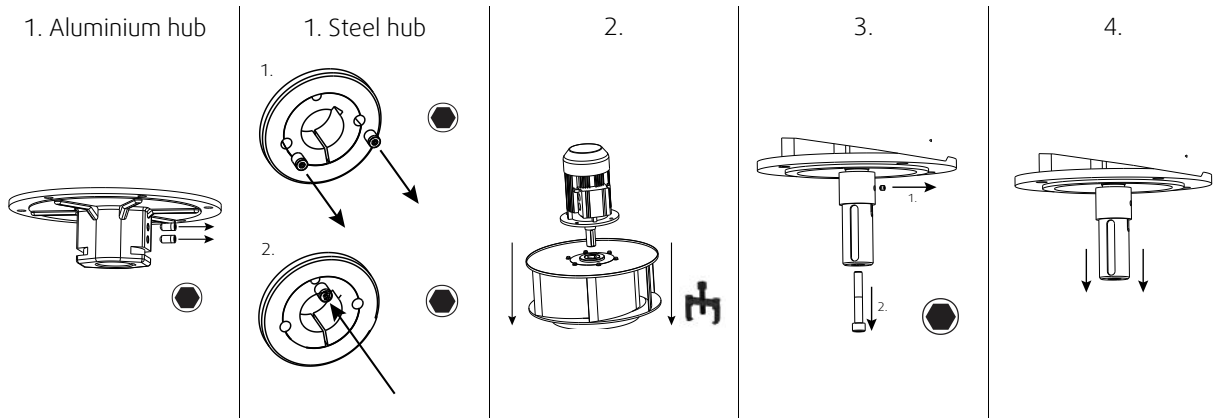

**Assembly**

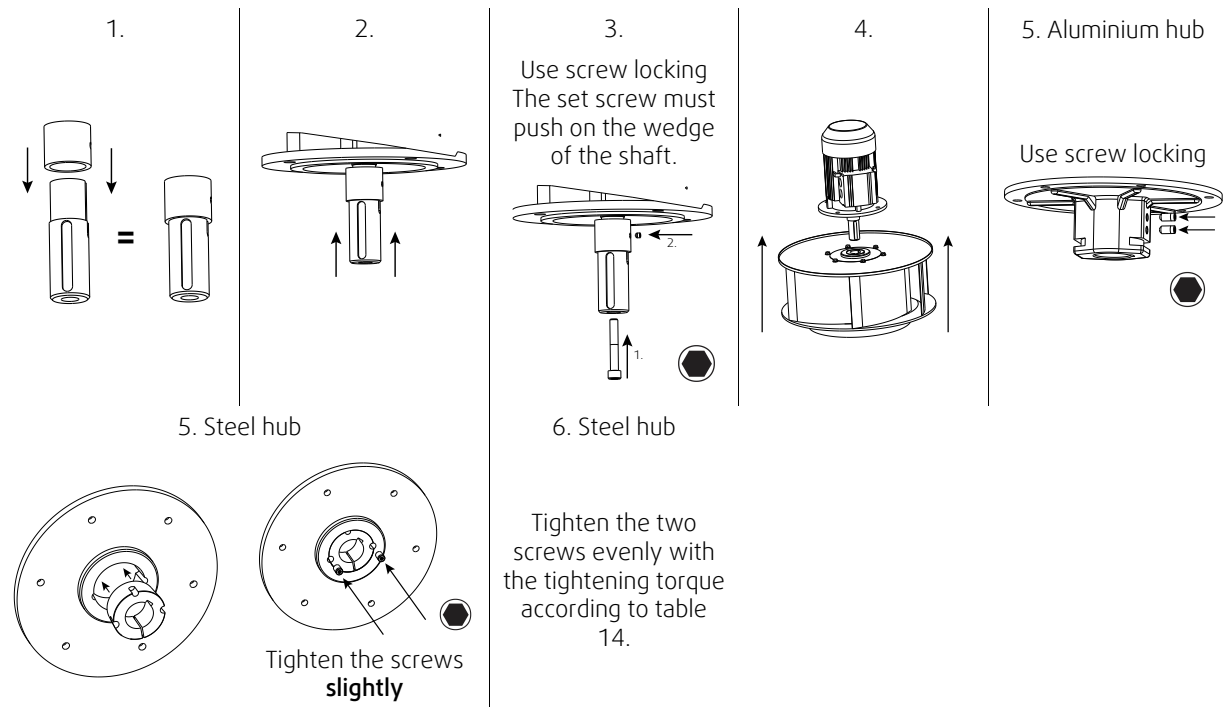

**Table 14 Tightening torques for various types of bush**

Type of bush	1008	1108	1210	1215	1310	1610	1615	2012	2517	3020
Tightening torque [Nm]	5.7	5.7	20	20	20	20	20	31	49	92

### 8.3 Assembly tilting device (FTG)



#### Warning

**Danger of injury by tilting the fan during installation.**

- ◆ The tilting device must be secured in the opened state by screws in the designated hole against unintentional folding.

#### Important

**Leaking duct system.**

- ◆ When installing the roof fan and accessories, all mounting surfaces have to be sealed air tight.

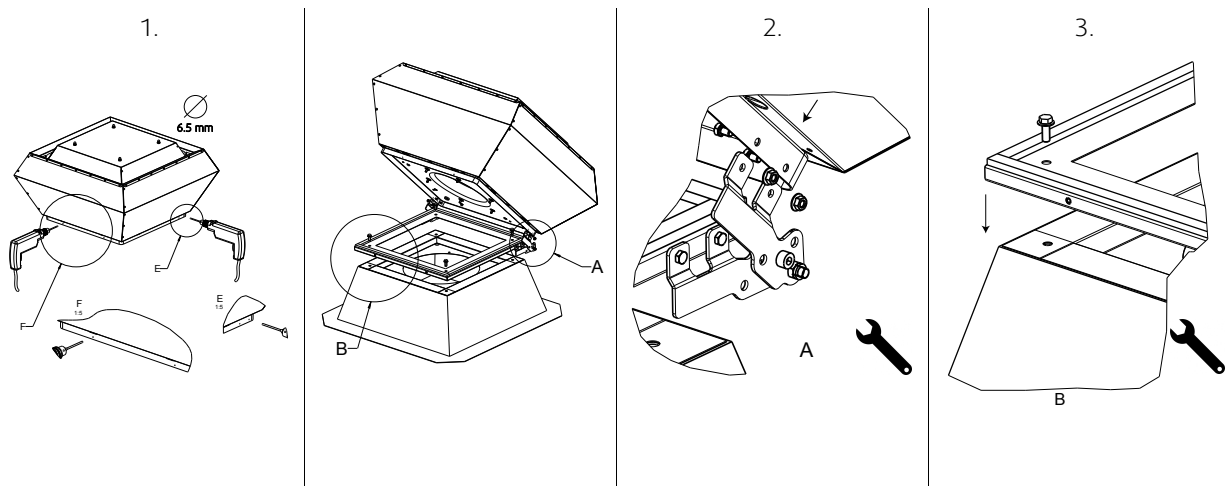

## 9 Electrical connection

### Safety information

**Warning: Danger from electrical voltage!**

- ◆ Observe the 5 rules of electrical safety, see 2.3 5 rules of electrical safety, page 2.
- ◆ Prevent the ingress of water into the connection box.
- ◆ Electrical connection may only be carried out by adequately qualified persons, details see Table 1 Qualifications, page 2.

**Warning: Danger due to electrostatic influence on medical implants!**

- ◆ Persons with medical implants should keep enough distance to the according devices.

## Connection

- ◆ Check if the data on the nameplate matches the connection data.
- ◆ Complete the electrical connection according to the circuit diagram.
- ◆ Fans with EC- motors must be switched on/off via the control input.
- ◆ Use all of the locking screws.
- ◆ Connect the cable end in a dry environment.
- ◆ Insert the screws by hand to avoid damaging the thread.
- ◆ Tighten all glands well in order to guarantee protection class IP.
- ◆ Screw the lid of the terminal box/inspection switch evenly tight.
- ◆ Install a circuit breaker in the permanent electrical installation, with a contact opening of at least 3 mm at each pole.

### Protective grounding wire

The protective grounding must have a cross-section equal to or greater than that of the phase conductor.

### Residual current circuit breaker

All-current-sensitive residual current circuit breakers are required for use in alternating-current systems with 50/60 Hz, in combination with electronic devices such as EC motors, frequency converters or uninterruptible power supplies (UPS).

## 9.1 Electrical connection accessories

The following wiring diagrams show the electrical connections between accessories and fans (with EC motor) or frequency converters (e.g. FRQ, FRQS, FXDM) which can be controlled with a 0–10V signal. If you are not sure if your fan is equipped with an EC- motor please see chapter 6 *Name plate and type key*, page 9.

motor/frequency converter



Wire- colours of motors with carried out cables: +10V = red      0..10V = yellow      GND = blue

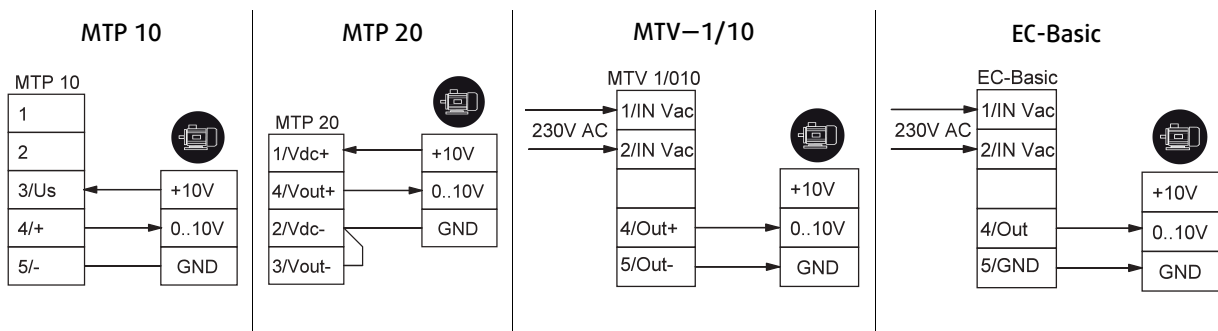

## 9.2 Protecting the motor



### Note:

In fans equipped with an EC motor, there is no additional motor protection needed. The motor protection is integrated in the electronics of the motor.

### Important

#### Damage to motor due to overcurrent, overload or short circuit.

- ◆ Lead-out temperature monitors must be integrated in the control circuit in such a way that, if a fault occurs, the motor cannot switch on again automatically after it has cooled down.
- ◆ Motor lines and temperature monitor lines should be laid separately on principle.
- ◆ Without thermal protection: Use a motor protection switch!

## 9.3 Variable-speed fans



### Warning

Resonant frequencies may result in increased vibration in certain speed ranges. These vibrations may destroy components.

- ◆ Only operate the fan outside these speed ranges.
- ◆ Pass through these speed ranges so quickly that any vibration cannot exceed the admissible resonant frequency values.
- ◆ Observe the operating instructions of the frequency converter.



### Caution

**Damage as a result of incorrect commissioning of the frequency converter.**

- ◆ Install the fan and frequency converter as near as possible to one another.
- ◆ Use shielded cables.
- ◆ All components (fan, frequency converter and motor) must be grounded.
- ◆ We recommend using all-pole sinus filters.
- ◆ Avoid running the fan via the frequency converter below 10 Hz.
- ◆ Heating of the motor due to use of a variable frequency drive must be checked in the application by the customer.
- ◆ Never exceed the maximum impeller rotation speed indicated on the name plate of the fan.

## 10 Commissioning

Warranty claims can only be made if commissioning work is carried out correctly and written evidence thereof is provided.

### Safety information

- ◆ Commissioning may only be carried out by adequately qualified persons, details see Table 1 *Qualifications*, page 2.

### Preconditions

- ◆ Installation and electrical connection have been correctly performed.
- ◆ Residual material from installation and foreign objects have been removed from the fan and ducts.
- ◆ Before switching the fan on, check for externally visible damage and ensure that the protective equipment functions properly.
- ◆ Inlet and outlet are free.
- ◆ Cable glands are tight.
- ◆ Data on the name plate corresponds with the connection data.
- ◆ Safety devices have been fitted.

### Tests

During commissioning, the following sequence must be observed:

#### AC motor

1. Switch the fan on.
2. Do the tests requested in the commissioning report (18 *Commissioning Report*, page 21)  
Speed controllable fans: "Measured data at commissioning" at maximum speed
3. Switch the fan off.

#### EC motor

When the mains are switched on, the motor starts an initialization (a few seconds). After the initialization the control input is active.

1. Switch the fan on via the control input.
2. Do the tests requested in the commissioning report (18 *Commissioning Report*, page 21)  
Speed controllable fans: "Measured data at commissioning" at maximum speed
3. Switch the fan off via the control input.

## 11 Operation

### Safety information

**Warning: Hazard from electrical voltage or moving components.**

- ◆ The device may only be operated by adequately qualified persons, details see Table 1 *Qualifications*, page 2.
- ◆ Only use the fan in accordance with the operating instructions and the operating instructions for the motor.

## 12 Troubleshooting/maintenance/repair

### Safety information

- ◆ Troubleshooting/maintenance/repair may only be carried out by adequately qualified persons, details see Table 1 *Qualifications*, page 2.
- ◆ Observe the 5 rules of electrical safety, see 2.3 *5 rules of electrical safety*, page 2.
- ◆ The impeller must be at a standstill.

### 12.1 Troubleshooting

**Table 15 Troubleshooting**

Problem	Possible causes	Remedy
Fan does not run smoothly	Impeller imbalance	Rebalancing by a specialist company if possible, otherwise contact Systemair.
	Soiling on the impeller	Clean carefully, rebalance
	Material decomposition on the impeller due to aggressive material conveyed.	Contact Systemair
	Impeller rotates in wrong direction.	Change direction of rotation if possible, otherwise contact Systemair.
	Deformation of impeller due to excessive temperature.	Ensure that the temperature does not exceed the certified value/Install new impeller.
Air output of fan too low	Vibrations, oscillations	Check the installation of the fan/check the duct system, see 8 <i>Installation</i> , page 11.
	Impeller rotates in wrong direction.	Change direction of rotation if possible, otherwise contact Systemair.
	Wrong wiring configuration (e.g. Y instead of Delta).	Check and possibly correct the wiring configuration.
	Pressure losses too high.	Optimize the line routing.
	Flow regulators not or only partly open.	Check opening position on site.
Grinding sounds when starting or operating the fan	Intake or pressure ducts are blocked.	Remove the blockage.
	Check if the duct connections of the fan are strained.	Loosen the duct connections and realign it.
Thermal contacts/resistors have triggered	Impeller rotates in wrong direction.	Change direction of rotation if possible, otherwise contact Systemair.
	Missing phase	In case of a 3 phase standard motor (not EC), check if all 3 phase are present.
	Motor overheated	Check the cooling impeller (if used), measure the motor winding (if possible) / contact Systemair.
	Capacitor (if used) not or not correctly connected.	Connect the capacitor correctly.
	Motor blocked	Contact Systemair

**Troubleshooting cont'd**

Fan does not reach nominal speed	Defective motor winding	Contact Systemair
	Improperly aligned drive motor	Contact Systemair
	Control units (if used) such as frequency converter or transformer are set incorrectly.	Correct the settings of the control units.
	Mechanical blockage	Remove the blockage.
Motor does not rotate	Faulty supply voltage	Check the supply voltage, re-establish the voltage supply.
	Faulty connection	Disconnect from the power supply, correct the connection, see circuit diagram.
	Temperature monitor has responded.	Allow the motor to cool down, find and resolve the cause of the fault.
Electronics/motor overheated	Insufficient cooling	Improve cooling.
	Overloaded motor	Check if the correct fan is used for your application.
	Ambient temperature too high	Check if the correct fan is used for your application.

**Note:**

For all other damage/defects, please contact Systemair. Defective safety-relevant fans (for Ex and smoke extraction applications) must be replaced completely.

**12.2 Maintenance**

**Warranty claims can only be made if maintenance work is carried out correctly and written evidence thereof is provided.**

We recommend regular maintenance intervals to ensure continuous fan operation. These maintenance intervals are specified in the "Activities" table below. In addition, the operator must carry out follow-up activities such as cleaning, replacing defective components or other corrective measures. For traceability reasons, a maintenance plan must be created which documents the work carried out. This must be created by the operator. If the operating conditions are "extreme", the maintenance intervals must be reduced so that maintenance is carried out more frequently. Examples of extreme operating conditions:

- Kitchen exhaust fans
- Ambient temperature > 40 °C or < -10 °C, or temperature fluctuations > 20 K

**Table 16 Activities**

Activity	Normal operating conditions		Extreme operating conditions	
	Every six months	Annually	Quarterly	Every six months
Check the fan and its components for visible damage, corrosion and contamination.		X		X
Check the impeller for damage and imbalance.		X		X
Check the condensate drain is working correctly.		X	X	
Clean the fan/ventilation system (see 13 <i>Cleaning</i> , page 19).	X		X	
Check the screwed connections for damages/defects and check that they are firmly seated.		X	See normal operating conditions	
Check the fan intake is free from contamination.		X		X
Check that the fan and its components are being used correctly.	X		See normal operating conditions	
Check the current consumption and compare this with the rated data.		X		X

**Activities cont'd**

Check the vibration dampers (if used) are working correctly and check for visible damage and corrosion.		X	See normal operating conditions
Check the electrical and mechanical protective equipment is working correctly.		X	See normal operating conditions
Check the fan's rating plate is legible.		X	X
Check the connection clamps and screwed cable connections for damage/defects, and check that they are firmly seated.		X	See normal operating conditions
Check the flexible connectors for damage.	X		See normal operating conditions

**Note:**

For all other damage/defects, please contact Systemair. Defective safety-relevant fans (for Ex and smoke extraction applications) must be replaced completely.

**12.3 Spare parts**

- ◆ Use original spare parts from Systemair only.
- ◆ When ordering spare parts, please specify the serial number of the fan. This can be found on the name plate.

**13 Cleaning****Safety information**

- ◆ Cleaning may only be carried out by adequately qualified persons, details see Table 1 *Qualifications*, page 2.
- ◆ Observe the 5 rules of electrical safety, see 2.3 *5 rules of electrical safety*, page 2.
- ◆ The impeller must be at a standstill.

**Procedure****Important****Keeping the fan clean extends its service life.**

- ◆ Install a filter monitor.
- ◆ Do not use steel brushes or sharp-edged objects.
- ◆ Do not use a high-pressure cleaner (steam jet cleaner) under any circumstances.
- ◆ Do not bend the fan blades when cleaning.
- ◆ When cleaning the impeller, pay attention to balance weights that have been positioned
- ◆ Keep the airways of the fan clear and clean them if necessary with a brush.

**14 Deinstallation/dismantling**

Deinstall and dismantle the fan in reverse order of installation and electrical connection.

**15 Disposal**

- ◆ Ensure material is recycled. Observe national regulations.
- ◆ The device and the transport packaging are predominantly made from recyclable raw materials.
- ◆ Disassemble the fan into its components.
- ◆ Separate the parts according to:
  - reusable material
  - material groups to be disposed of (metal, plastics, electrical parts, etc.)

## 16 EU Declaration of conformity – Roof fans

**Table 17 Roof fans**

<b>The manufacturer:</b>	Systemair GmbH Seehöfer Straße 45 97944 Boxberg Germany
<b>Product designation:</b>	Roof fans
<b>Type designation:</b>	DVS; DHS; DVSI; DVC/DVCI; DVP
<b>Since year of manufacture:</b>	2016

The manufacturer declares that the above mentioned products in their design and construction and the version marketed by us complies with the harmonization legislation listed below:

<b>EU directives:</b>	2006/42/EC	Machinery directive
	2014/30/EU	Directive electromagnetic compatibility (EMC)
	2011/65/EU	RoHS directive
	2009/125/EC	ErP guidelines
<b>Regulations:</b>	1253/2014	Only for ventilation units above 30W

## 17 EU Declaration of conformity – Thermo fans

<b>The manufacturer:</b>	Systemair GmbH Seehöfer Straße 45 97944 Boxberg Germany
<b>Product designation:</b>	Thermo fans
<b>Type designation:</b>	AxZent; KBR; MUB-K; MUB/T; MUB/T-S; DVN; DVNI
<b>Since year of manufacture:</b>	2018

The manufacturer declares that the above mentioned products in their design and construction and the version marketed by us complies with the harmonization legislation listed below:

<b>EU directives:</b>	2006/42/EC	Machinery directive
	2014/30/EU	Directive electromagnetic compatibility (EMC)
	2011/65/EU	RoHS directive



## 18 Commissioning Report

Warranty claims can only be made if commissioning work is carried out correctly and written evidence thereof is provided.

### Fan

Description:

Article no.:

Manufacturing order no.:

### Installer

Company:

Contact person:

Company address:

Tel. no.:

Email:

### Operator (Place of installation)

Company:

Contact person:

Company address:

Tel. no.:

Email:

### Type of connection

Yes No

Directly to mains

0-10 V signal (EC motor)

via contactor control

Transformer

Frequency converter

Sinus filter

Shielded cables

### Motor protection

Yes No

Motor protection switch or motor protection relay

PTC resistor

Resistance value [ $\Omega$ ]:

Thermal contact

Electrical motor protection

Others:

### Functional check

Yes No

Impeller easily rotatable (by hand)

Rotation direction acc. to directional arrow

Smooth running without unusual noise/  
vibrations

### Nominal data - Fan (name plate on fan housing)

Voltage [V]:

Current [A]:

Frequency [Hz]:

Power [kW]:

Fan impeller speed [rpm]:

### Measured data at commissioning

Voltage [V]:

Temp. of transported air [ $^{\circ}$ C]:

Current L1 [A]*:	Fan impeller speed [rpm]:
Current L2 [A]:	Air volume [m3/s]:
Current L3 [A]:	Differential pressure [Pa]*:
<small>*For single-phase fans, fill in line "Current L1 [A]"</small>	<small>*Δ- Pressure between suction-side and discharge of the fan</small>

If an air flow measurement is not possible, this value can be calculated using the following formula:

$$\frac{\text{Duct cross-section [m}^2\text{]}}{\text{Flow speed [m/s]}} = \text{Air volume [m}^3\text{/s]:}$$

Grille measurement acc. to VDI 2044

	Yes	No
Commissioning of the fan successful?	<input type="checkbox"/>	<input type="checkbox"/>

\_\_\_\_\_  
Date, installer's signature

\_\_\_\_\_  
Date, operator's signature





Systemair GmbH  
Seehöfer Str. 45  
97944 Boxberg  
Germany

Tel.: +49 (0)7930/9272-0  
Fax: +49 (0)7930/9273-92

[info@systemair.de](mailto:info@systemair.de)  
[www.systemair.de](http://www.systemair.de)